

- PETROL ENGINE TWIN CAMSHAFT & DIESEL ENGINE TIMING TOOL KIT
- KIT CALAGE MOTEUR ESSENCE DOUBLE ARBRE A CAME & DIESEL
- KIT CALADO MOTOR GASOLINA DOBLE ARBOL DE LEVAS Y DIESEL
- BENZINEMOTOREN AFSTELSET DUBBELE NOKKENAS & DIESEL
- ARRETIERWERKZEUG-SATZ FÜR DOPPELNockenWELLEN UND OT-EINSTELLUNG DER BENZIN - UND DIESELMOTOREN

No.9AT1406



www.kingtony.com

The brand you trust for life

- The kit includes VCT setting plate, camshaft setting plate, crankshaft TDC location pin, tensioner locking pin and flywheel locking tool.
- Suitable for 16v. DURATEC petrol engine of Ford 1.6 Ti-VCT twin camshaft.
- Use to adjust VCT timing on inlet and exhaust camshaft during timing belt replacement.

FORD	
MODEL	ENGINE
B-Max / C-Max / Focus / Galaxy / Grand C-Max/Mondeo/S-Max	1.6 SCTi/Ti-VCT Ecoboost petrol
VOLVO	
MODEL	ENGINE
S60/S80/V60/V70	1.6GTDI

CONTENTS:

- A&E - Flywheel Locking Tool
- B - Camshaft Setting Plate
- C - Crankshaft TDC Location Pin
- D - Tensioner Locking Pin
- F - VCT Setting Plate
- G - Crankshaft Pulley Alignment Tool

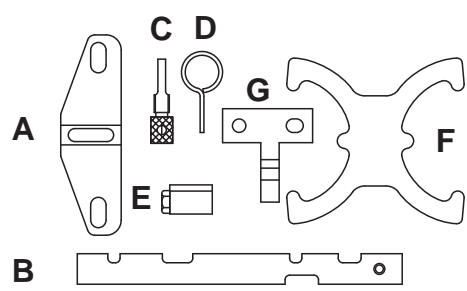

- Ce kit contient une platine de réglage VCT, une Platine de réglage d'arbre à came, une pige de verrouillage vilebrequin TDC, une Pige de blocage de galet tendeur et un outil de maintien volant moteur.
- Compatible moteurs essence duratec Ford 1.6 Ti-VCT double arbres à cames.
- Permet de régler la distribution VCT sur l'arbre à cames d'admission et d'échappement lors du remplacement de courroie de distribution.

FORD	
MODELES	ENGINE
B-Max / C-Max / Focus / Galaxy / Grand C-Max/Mondeo/S-Max	1.6 SCTi/Ti-VCT Ecoboost petrol
VOLVO	
MODELES	ENGINE
S60/S80/V60/V70	1.6GTDI

CONTIENT :

- A&E - outil de maintien volant moteur
- B - Platine de réglage d'arbre à came
- C - pige de verrouillage vilebrequin TDC
- D - Pige de blocage de galet tendeur
- F - Platine de réglage VCT
- G - Crankshaft Pulley Alignment Tool

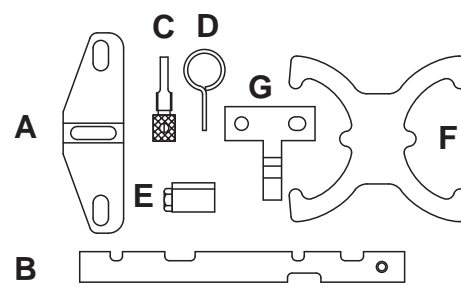

- Este kit contiene un platino de reglaje VCT, un platino de reglaje de árbol de levas, un varilla de cierre berbiquí TDC, una varilla de bloqueo de rodillo tensor, y una herramienta para aguantar el volante motor.
- Compatible motores gasolina DURATEC Ford 1.6 Ti-VCT doble árbol de levas.
- Permite arreglar la distribución VCT sobre el árbol de levas de admisión y de escape, durante el reemplazo de la correa de distribución.

FORD	
MÓDELOS	ENGINE
B-Max / C-Max / Focus / Galaxy / Grand C-Max/Mondeo/S-Max	1.6 SCTi/Ti-VCT Ecoboost petrol
VOLVO	
MÓDELOS	ENGINE
S60/S80/V60/V70	1.6GTDI

CONTIENE :

- A&E - herramienta para aguantar el volante motor
- B - platino de reglaje de árbol de levas
- C - varilla de cierre berbiquí TDC
- D - varilla de bloqueo de rodillo tensor
- F - platino de reglaje VCT
- G - Crankshaft Pulley Alignment Tool

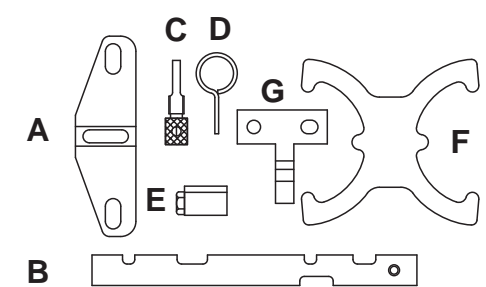

- Deze set bevat een VCT-afstelplaat, een borgpen om de krukas te blokkeren, een borgpen om de spanrol af te stellen TDC, en een gereedschap om het vliegwiel vast te houden.
- Geschikt voor benzinemotoren Ford 1.6 Ti-VCT dubbele nokkenas.
- Om de VCT-distributie op de inlaat en uitlaat nokkenas af te stellen tijdens het vervangen van de distributieriem.

FORD	
MODELLEN	ENGINE
B-Max / C-Max / Focus / Galaxy / Grand C-Max/Mondeo/S-Max	1.6 SCTi/Ti-VCT Ecoboost petrol
VOLVO	
MODELLEN	ENGINE
S60/S80/V60/V70	1.6GTDI

INHOUD:

- A&E - Gereedschap om het vliegwiel vast te houden
- B - Afstelgereedschap voor nokkenas
- C - Borgpen om de krukas te blokkeren TDC
- D - Borgpen om de spanrol te blokkeren
- F - VCT-afstelplaat
- G - Crankshaft Pulley Alignment Tool

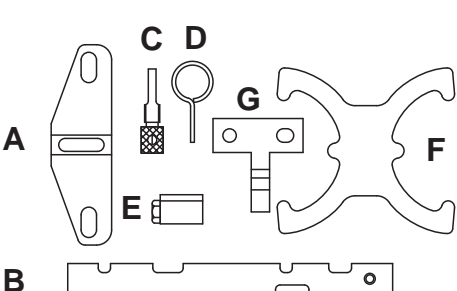

- Der Satz enthält VCT-Einstellplatte, Nockenwellen- Einstellplatte, Kurbelwellen-OT-Einstellstift, Spanner-Arretierstift und Schwungrad-Arretierwerkzeug.
- Passend für Ford -16V DURATEC- -Dieselmotor, 1,6Ti-VCT Doppelnockenwellen.
- Erforderlich zum VCT-OT-Einstellung auf Einlass-und Auslass der Nockenwellen beim Zahnriemenwechsel.

FORD	
MODELL	ENGINE
B-Max / C-Max / Focus / Galaxy / Grand C-Max/Mondeo/S-Max	1.6 SCTi/Ti-VCT Ecoboost petrol
VOLVO	
MODELL	ENGINE
S60/S80/V60/V70	1.6GTDI

INHALT :

- A&E - Schwungrad-Arretierwerkzeug
- B - Nockenwellen- Einstellplatte
- C - Kurbelwellen-OT-Einstellungsstift
- D - Spanner-Arretierstift
- F - VCT- Einstellplatt
- G - Crankshaft Pulley Alignment Tool

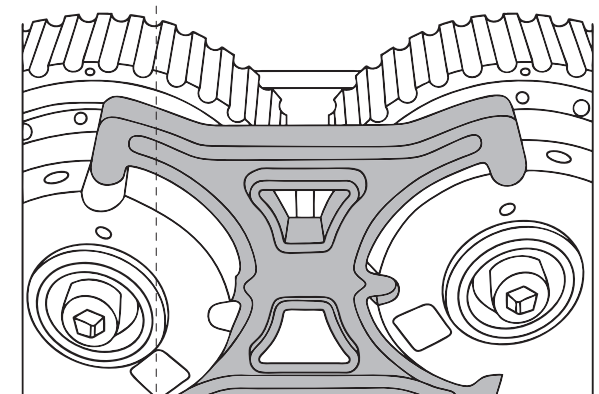
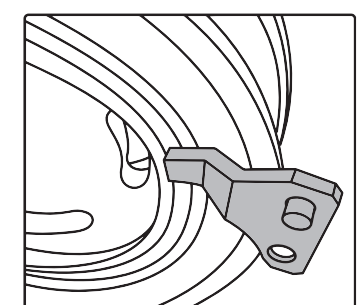
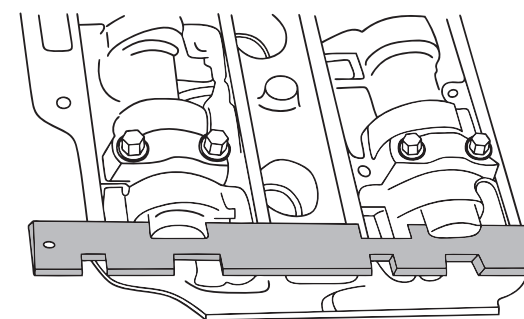
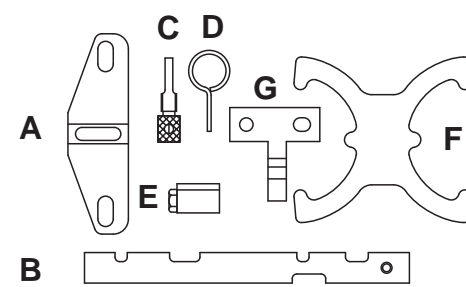

- Start motor
- Démarrage moteur/démarrreur
- Arranque motor
- Startmotor
- Startermotor/Anlasser

