

- Engine Setting & Locking Tool
 - Kit de Calage
 - Kit de Calado
 - Afstelset
 - Motoreinstell- & Arretierwerkzeug
- NO.9AT1506E



www.kingtony.com

Enjoy your work

- The kit includes dial & TDC indicator and camshaft setting tool
- Suitable for 1.2/1.4T FSi and 1.4/1.6 FSi engines
- Use to check and adjust engine timing

MODEL	Audi A1(10-12) / A3(03-12) Seat Altea / Altea XL(08-12) / Ibiza / Cordoba(08-12) / Leon(07-12) / Toledo(07-09) Skoda Fabia II(07-12) / Octavia II(04-12) / Roomster(06-12) / Superb II(09-12) / Yeti(09-12) VW Caddy/ Caddy Maxi(10-12) / Eos(06-12) / Golf(03-12) / Golf Plus(03-12) / Jetta(06-12) / Passat(05-11) / Polo(02-12) / Scirocco(08-12) / Tiguan(07-12) / Touran(03-12)
ENGINE	1.2T FSi CBZA / CBZB/ CBZC 1.4T FSi BLG / BMY / BWK / CAVA / CAVB / CAVC / CAVD / CAVE / CAVF / CAXA / CAXC / CDGA / CSMA 1.4 FSi AXU / BKG / BLN 1.6 FSi BAG / BLF / BLP / BTS

CONTENTS:

- A - Camshaft setting plate
- B - TDC indicator
- C - Camshaft setting tool
- D - Crankshaft locking pin
- E - Dial test indicator
- F - Tensioner locking pin

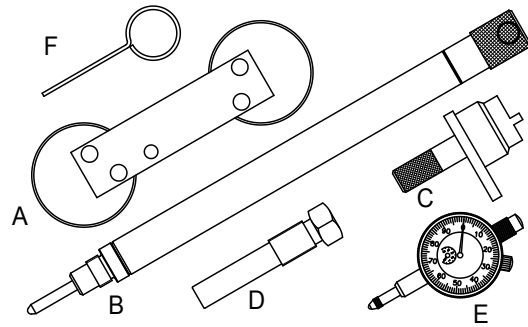

- Kit inclut un gauge et un indicateur du point mort haut et un outil de calage d'arbre à cames
- Convient pour moteurs 1.2/1.4T FSi et 1.4/1.6 FSi
- Utilisé pour vérifier et ajuster le calage moteur

MODELE	Audi A1(10-12) / A3(03-12) Seat Altea / Altea XL(08-12) / Ibiza / Cordoba(08-12) / Leon(07-12) / Toledo(07-09) Skoda Fabia II(07-12) / Octavia II(04-12) / Roomster(06-12) / Superb II(09-12) / Yeti(09-12) VW Caddy/ Caddy Maxi(10-12) / Eos(06-12) / Golf(03-12) / Golf Plus(03-12) / Jetta(06-12) / Passat(05-11) / Polo(02-12) / Scirocco(08-12) / Tiguan(07-12) / Touran(03-12)
MOTEUR	1.2T FSi CBZA / CBZB/ CBZC 1.4T FSi BLG / BMY / BWK / CAVA / CAVB / CAVC / CAVD / CAVE / CAVF / CAXA / CAXC / CDGA / CSMA 1.4 FSi AXU / BKG / BLN 1.6 FSi BAG / BLF / BLP / BTS

CONTENU:

- A - Plaque de calage d'arbre à cames
- B - Indicateur du point mort haut
- C - Outil de calage d'arbre à cames
- D - Goupille de blocage du vilebrequin
- E - Gauge de test
- F - Goupille de blocage pour tendeur

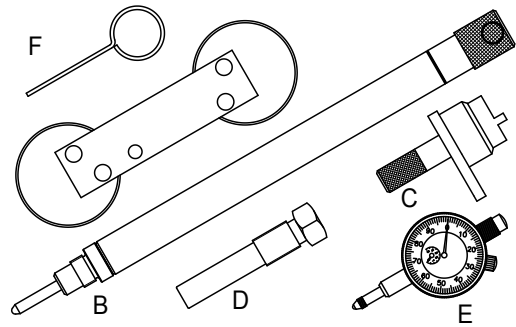

- Este kit incluye un comparador de prueba, un indicador del punto muerto alto, y una herramienta de calado del árbol de levas
- Conviene para los motores 1.2/1.4T FSi y 1.4/1.6 FSi
- Se utiliza para comprobar y arreglar el calado motor

MODELO	Audi A1(10-12) / A3(03-12) Seat Altea / Altea XL(08-12) / Ibiza / Cordoba(08-12) / Leon(07-12) / Toledo(07-09) Skoda Fabia II(07-12) / Octavia II(04-12) / Roomster(06-12) / Superb II(09-12) / Yeti(09-12) VW Caddy/ Caddy Maxi(10-12) / Eos(06-12) / Golf(03-12) / Golf Plus(03-12) / Jetta(06-12) / Passat(05-11) / Polo(02-12) / Scirocco(08-12) / Tiguan(07-12) / Touran(03-12)
MOTOR	1.2T FSi CBZA / CBZB/ CBZC 1.4T FSi BLG / BMY / BWK / CAVA / CAVB / CAVC / CAVD / CAVE / CAVF / CAXA / CAXC / CDGA / CSMA 1.4 FSi AXU / BKG / BLN 1.6 FSi BAG / BLF / BLP / BTS

CONTENIDO:

- A - Placa de calado del árbol de levas
- B - Indicador del punto muerto alto
- C - Herramienta de calado del árbol de levas
- D - Varilla de bloqueo del berbiquí
- E - Comparador de prueba
- F - Varilla de bloqueo para tensor

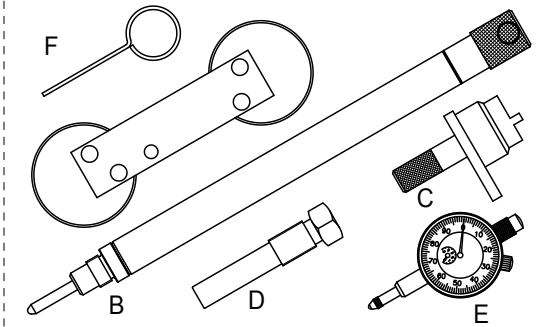

- kit bevat een graadmeet apparaat en een bovenste dode punt indicator voor het afstellen van de nokkenas gereedschap
- Geschikt voor motoren 1.2 / 1.4T FSi en 1.4 / 1.6 FSi
- Gebruikt om te controleren en aanpassen van de motor afstelling

MODEL	Audi A1(10-12) / A3(03-12) Seat Altea / Altea XL(08-12) / Ibiza / Cordoba(08-12) / Leon(07-12) / Toledo(07-09) Skoda Fabia II(07-12) / Octavia II(04-12) / Roomster(06-12) / Superb II(09-12) / Yeti(09-12) VW Caddy/ Caddy Maxi(10-12) / Eos(06-12) / Golf(03-12) / Golf Plus(03-12) / Jetta(06-12) / Passat(05-11) / Polo(02-12) / Scirocco(08-12) / Tiguan(07-12) / Touran(03-12)
MOTOR	1.2T FSi CBZA / CBZB/ CBZC 1.4T FSi BLG / BMY / BWK / CAVA / CAVB / CAVC / CAVD / CAVE / CAVF / CAXA / CAXC / CDGA / CSMA 1.4 FSi AXU / BKG / BLN 1.6 FSi BAG / BLF / BLP / BTS

Bevat :

- A - Nokkenas afstelplaat
- B - Een bovenste dode punt indicator
- C - Nokkenas afstel gereedschap
- D - Krukas borgpen
- E - Testmanometer
- F - Spanner borgpen

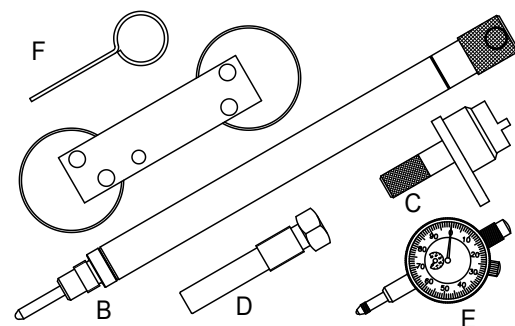

- Dieses Kit beinhaltet eine Messuhr und einen OT-Indikator sowie ein Einstellwerkzeug für Nockenwelle
- Geeignet für 1.2/1.4T FSi und 1.4/1.6 FSi Motoren
- Verwenden um die Motorsteuerung zu prüfen oder anzupassen

MODELL	Audi A1(10-12) / A3(03-12) Seat Altea / Altea XL(08-12) / Ibiza / Cordoba(08-12) / Leon(07-12) / Toledo(07-09) Skoda Fabia II(07-12) / Octavia II(04-12) / Roomster(06-12) / Superb II(09-12) / Yeti(09-12) VW Caddy/ Caddy Maxi(10-12) / Eos(06-12) / Golf(03-12) / Golf Plus(03-12) / Jetta(06-12) / Passat(05-11) / Polo(02-12) / Scirocco(08-12) / Tiguan(07-12) / Touran(03-12)
MOTOR	1.2T FSi CBZA / CBZB/ CBZC 1.4T FSi BLG / BMY / BWK / CAVA / CAVB / CAVC / CAVD / CAVE / CAVF / CAXA / CAXC / CDGA / CSMA 1.4 FSi AXU / BKG / BLN 1.6 FSi BAG / BLF / BLP / BTS

INHALTE:

- A - Einstellplatte für die Nockenwelle
- B - OT-Indikator
- C - Nockenwellen-Fixierwerkzeug
- D - Kurbelwellen-Arretierstift
- E - Messuhr
- F - Spann-Arretierstift

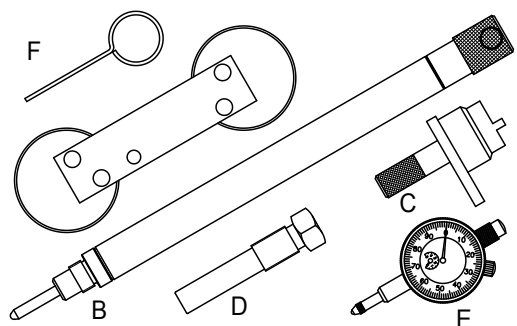

- Used on the 1.2 TSi engines valve timing (CBZA/CBZB)
- Utilisé sur le calage de soupapes des moteurs 1.2 TSi (CBZA/CBZB)
- Se utiliza sobre el calado de válvulas de los motores 1.2 TSi (CBZA/CBZB)
- Gebruikt om de kleptiming van de motor af te stellen 1.2 TSi (CBZA / CBZB)
- auf 1.2 TSi Motoren-Ventilsteuerung (CBZA/CBZB) verwenden

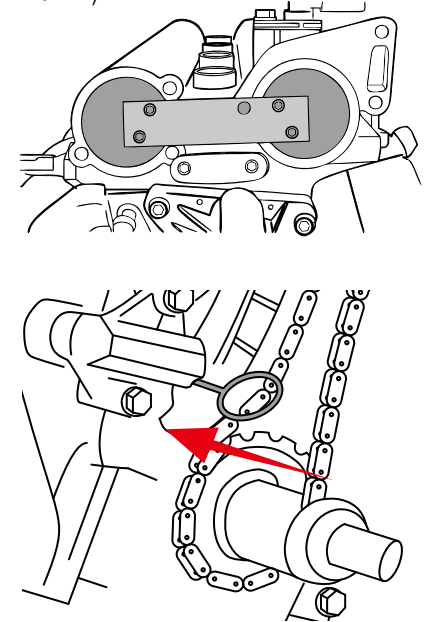
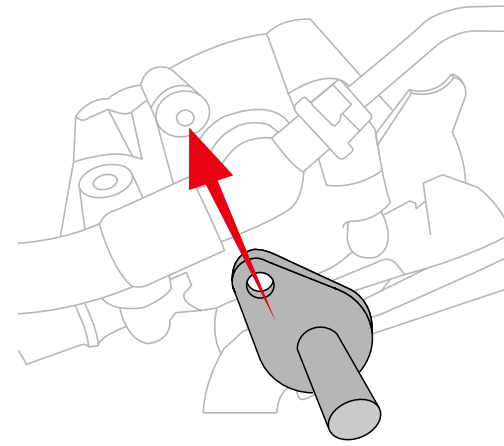

- Measure the cylinder piston at TDC position
- Mesurer le cylindre piston en position du point mort haut
- Medir el cilindro pistón en posición del punto muerto alto
- Meet de cilinder zuiger het bovenste dode punt
- Zylinderkolben auf OT-Position messen

- Fit the crankshaft locking pin
- Installer la goupille de blocage de l'arbre à cames
- Colocar la varilla de bloqueo del árbol de levas
- Installeer de adapter plaat aan de nokkenas
- Kurbelwellen-Arretierstift einsetzen

